

Our Diamond Aircraft Fleet

Diamond Aircraft's fleet of certified, composite aircraft represents the best engineered and most competent aircraft in the market. It also holds one of the best safety records on the General Aviation market and is the most efficient GA aircraft flying today. Just like Diamond Aircraft, Sea Land Air is committed to bringing leading edge technology to the market. With our fleet of Diamond Aircraft, including DA20-A1, DA20-C1, DA40 and DA42 TDI, we are proud to be able to provide students and pilots with exceptional aviation experiences.

Aircraft Specifications:

	DA20-A1	DA20-C1	DA40	DA42 TDI (Twin)
Engine	Rotax 912	TCM IO-240-B3B	Lycoming IO-360-M1A	Centurion 2.0 turbo Diesel
Horsepower	100 hp	125 hp	180 hp	270 hp
Wing Span	35 ft 6.7 in	35 ft 8 in	39 ft 2 in	44 ft
Max. T/O Weight	1,653 lbs	1,764 lbs	2,535 lbs	3,935 lbs
Fuel capacity, usable	19.5 gal	24.0 gal	48.0 gal	50.0 gal (76.4 gal with aux. tanks)
Stall speed, full flaps	37 kts	45 kts	49 kts	57 kts (Gear down)
Max. demonstrated crosswind	15 kts	20 kts	20 kts	20 kts

Three-View Drawing of DA20-C1 Aircraft

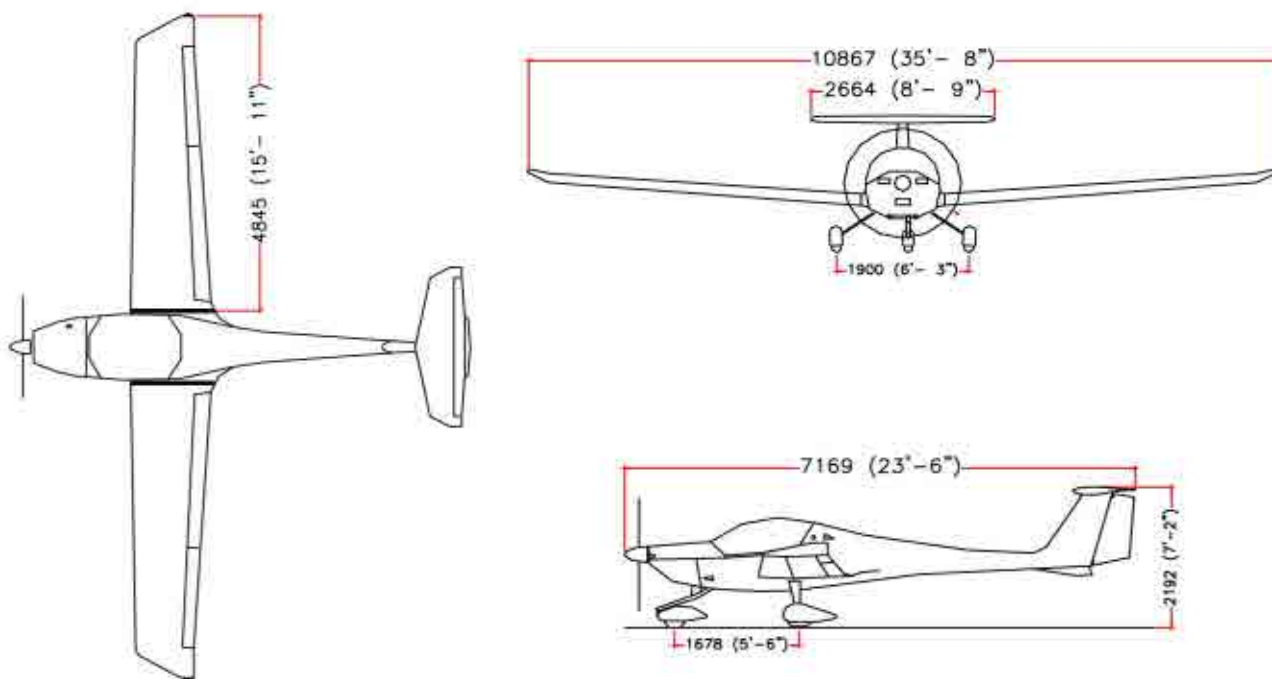

Three-View Drawing of Diamond DA40

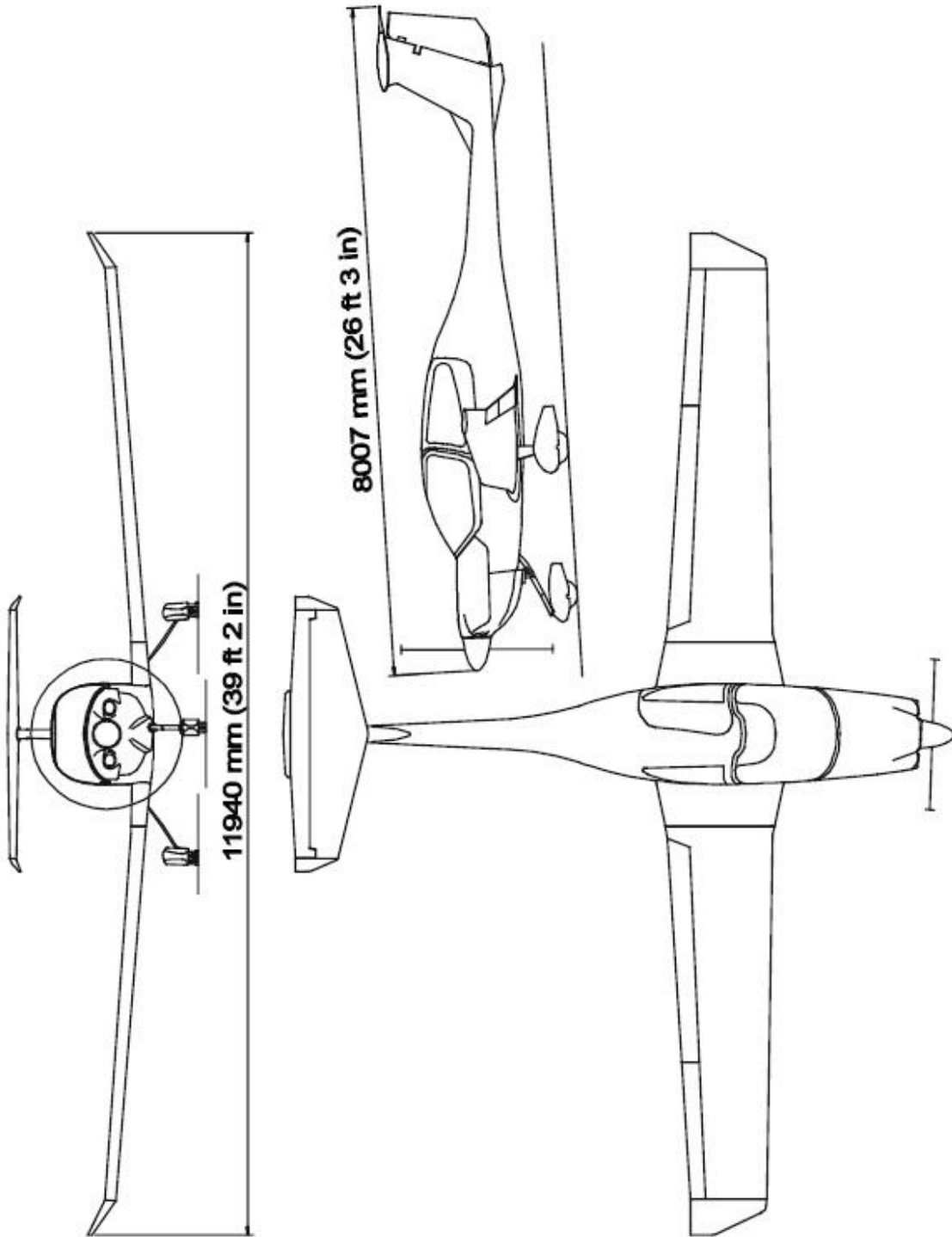

Three-View Drawing of Diamond DA42 TDI

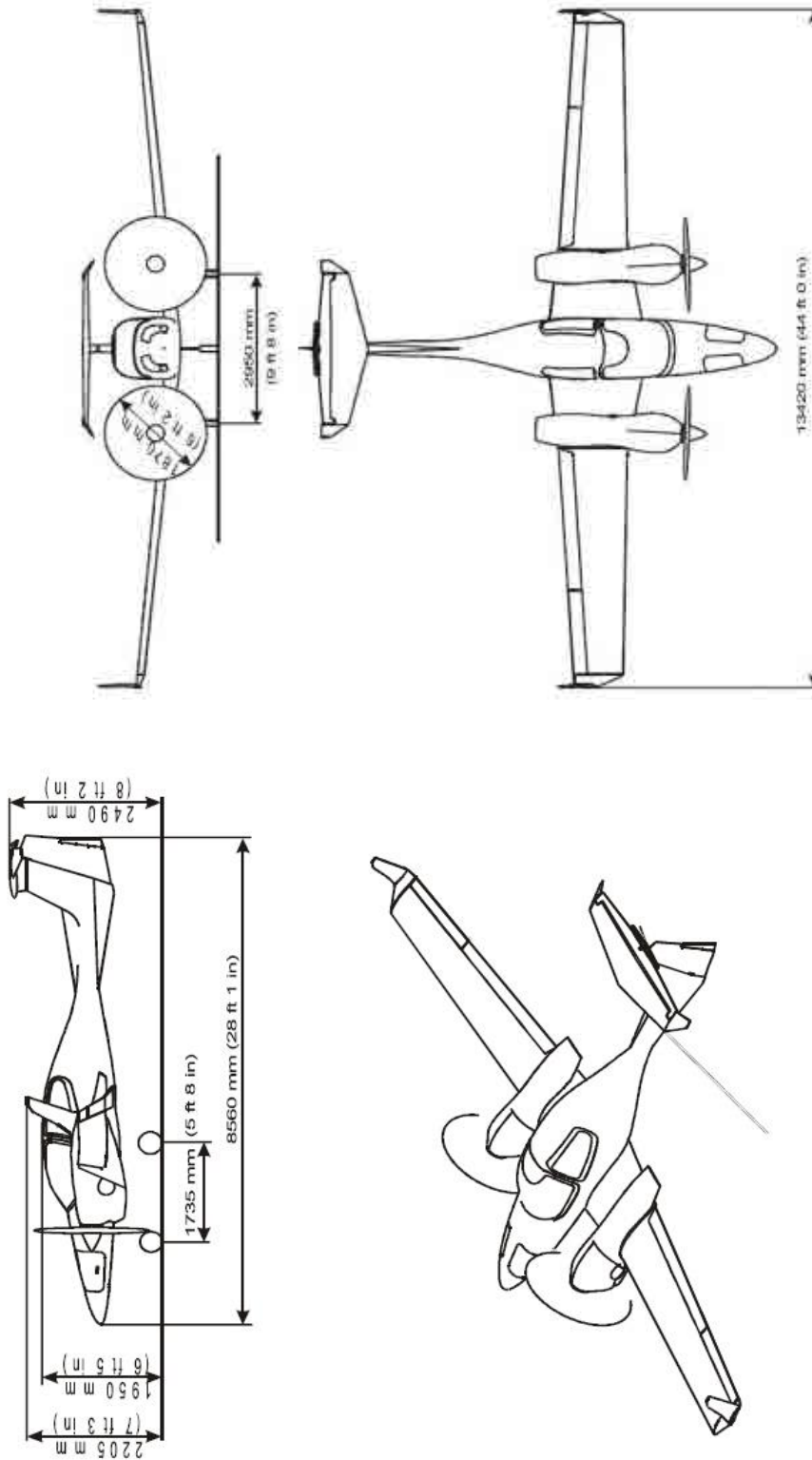

Private Pilot License

Whether you're training for a hobby or a career, this is where it all begins. This is the most important phase of your training where you develop good discipline, habits and attitudes for safe and proficient flight. At the end of this course, you will obtain a Canadian Private Pilot License. You can fly virtually anywhere under Visual Flight Rules (VFR) while taking passengers along for the adventure. With this licence you can expand your privileges by adding ratings such as a night rating, float rating, and/or multi engine rating.

Licensing Requirements:

Age

You must be at least 17 years of age at the completion of the course.

Medical Fitness

You must hold either a Category 1 or a Category 3 Medical Certificate.

Knowledge

You must complete a minimum of 40 hours private pilot aeroplane ground school instruction on the following subjects:

- Canadian Aviation Regulations
- Aerodynamics and Theory of Flight
- Meteorology
- Airframes, Engines and Systems
- Flight Instruments
- Radio and Electronic Theory
- Navigation
- Flight Operations
- Licensing Requirements
- Human Factors, including pilot decision-making

You must obtain a minimum of 60% in each of the following four mandatory subject areas as well as in the overall written examination Private Pilot Licence - Aeroplane (PPAER):

- Air law
- Navigation
- Meteorology
- Aeronautics and General Knowledge

Experience

A minimum of 45 hours of flight training must be accomplished in aeroplanes, with a maximum of 5 hours of these 45 hours may be conducted in an approved flight simulator. At least 17 of these hours must be dual, of which at least 3 hours must be cross-country flight and 5 hours of instrument time. 3 hours of the instrument time may be conducted in a simulator. The student pilot must also have a minimum of 12 hours solo experience which must include at least 5 hours of cross country time.

Skill

Upon reaching a proficient skill level, the student pilot will complete a Private Pilot Flight Test as per the Flight Test Standards Guide, conducted by a Transport Canada Designated Flight Test Examiner.

Language Proficiency

Students of the Private Pilot Licence Program or the Recreational Pilot Permit Program are required to undertake the "Formal Aviation Language Proficiency Demonstration" with a Transport Canada Language assessor and demonstrate an operational or expert level of language proficiency before any solo flights.

Exceptions are:

- Canadian citizens who have graduated from a Canadian English or French speaking high school and can provide the evidence that they have completed their studies in either English or French.
- Canadian citizens who have not yet finished their high school but can provide proof of attendance (e.g., report cards, enrollment papers).

Note: Prices are based on Transport Canada's minimum requirement of 45 hour total time. Students may require additional flight training hours and ground briefing time before being ready for flight test. All prices are in CAD and are subject to change without prior notice. An hourly fuel surcharge will apply due to fuel price fluctuation.

This program does not require approval by the registrar of the Private Training Institutions Branch (PTIB) of the Ministry of Advanced Education, Skills & Training. As such, the registrar did not review this program.

	Training Costs		
	DA20-A1 @ \$160/hr solo \$233/hr dual	DA20-C1 @ \$180/hr solo \$253/hr dual	DA40 @ \$265/hr solo \$338/hr dual
Aviation Medical Examination (fee is subject to each medical examiner)	\$200.00	\$200.00	\$200.00
30 hours Dual Flight	\$6,990.00	\$7,590.00	\$10,140.00
15 hours Solo Flight	\$2,400.00	\$2,700.00	\$3,975.00
10 hours of pre-flight and post-flight ground briefings (\$73/hour)	\$730.00	\$730.00	\$730.00
40 hours Ground School Course	\$550.00	\$550.00	\$550.00
Ground School Kit	\$185.00	\$185.00	\$185.00
Aviation Language Proficiency Test fee	\$130.00	\$130.00	\$130.00
Written Examination	\$210.00	\$210.00	\$210.00
Flight Test (1.5hr Aircraft rental + Flight test fee \$400)	\$640.00	\$670.00	\$797.50
Licensing fee (school AP fee + Transport Canada fee)	\$175.00	\$175.00	\$175.00
Total Estimated Cost:	\$12,210.00	\$13,140.00	\$17,092.50

Commercial Pilot License

This licence allows you to fly for hire and reward. Commercial pilots do not always have the luxury of choosing the day they fly as there are schedules to meet, the company has a profit to make, and the passengers or cargo have to get to where they are going. And they are all relying on your professional planning, skill, knowledge and experience. The Commercial Pilot course is all about perfecting your abilities and raising your skills to a higher level from the Private Pilot standard.

In addition, you will learn:

- the skills to adapt to a different aircraft type through type check rides of various aircraft
- mountain flying skills

Admission Requirements:

- Private Pilot License
- Category 1 Medical Certificate

Licensing Requirements:

Age

You must be a minimum of eighteen years of age at the completion of the course.

Medical Fitness

You must hold a valid Category 1 Medical Certificate.

Knowledge

You must complete a minimum of 80 hours commercial pilot aeroplane ground school instruction including at least the following subjects:

1. Canadian Aviation Regulations
2. Aerodynamics and theory of flight
3. Meteorology
4. Airframes, engines and systems
5. Flight instruments
6. Radio and electronic theory
7. Navigation
8. Flight operations
9. Licensing requirements, and
10. Human factors including pilot decision-making

You must obtain a minimum of 60% in each of the following four mandatory subjects areas as well as in the overall written examination Commercial Pilot Licence — Aeroplane (CPAER)

1. Air law
2. Navigation
3. Meteorology
4. Aeronautics and General Knowledge

Experience

You must have:

A minimum of 200 hours flight time in aeroplanes, of which a minimum of 100 hours shall be pilot in command time including 20 hours cross-country pilot-in-command flight time.

following the issuance of a private pilot licence — aeroplane by Canada or another contracting state, 65 hours of commercial pilot flight training in aeroplanes consisting of a minimum of:

35 hours dual instruction flight time, under the direction and supervision of the holder of a Flight Instructor Rating — Aeroplane, including:

- 5 hours night, including a minimum of 2 hours of cross-country flight time
- 5 hours cross-country, which may include the above the night cross-country experience
- 20 hours of instrument flight time. A maximum 10 hours of the 20 hours may be conducted on an approved aeroplane simulator or synthetic flight training device

30hours solo flight time including:

- 25 hours solo flight time emphasizing the improvement of general flying skills of the applicant which shall include a cross-country flight to a point of a minimum of 300 nautical mile radius from the point of departure and shall include a minimum of 3 landings at points other than that of departure.
- 5 hours solo flight time by night during which a minimum of 10 takeoffs, circuits and landings were completed

Skill

Within the 12 months preceding the date of application for the licence, an applicant for a commercial pilot licence — aeroplane shall successfully complete a flight test to the standard outlined in the Flight Test Guide Commercial Pilot Licence — Aeroplane

Note: Prices are based on Transport Canada minimum requirements and also based on that a student has completed 45 hours total flight time to obtain PPL. In the case of including hours from the Multi Rating and Instrument Rating toward the CPL total flight time required (200 hours) the total estimate cost will be reduced. All prices are in CAD and are subject to change without prior notice. An hourly fuel surcharge will apply due to fuel price fluctuation.

This program has been approved by the registrar of the Private Training Institutions Branch (PTIB) of the Ministry of Advanced Education, Skills & Training.

	Training Costs	
	DA20-A1 @ \$160/hr solo \$233/hr dual	DA20-C1 @ \$180/hr solo \$253/hr dual
Aviation Medical Examination (fee subject to each medical examiner)	\$200.00	\$200.00
CPL Admission fee	\$120.00	\$120.00
35 hours Dual Flight Training	\$8,155.00	\$8,855.00
120 hours Solo Flight Time	\$19,200.00	\$21,600.00



5 hours of Ground Briefings (\$73/hour)	\$365.00	\$365.00
80 hours Commercial Ground School Course (fee subject to ground school provider)	\$300.00	\$300.00
Written Examination	\$109.24	\$109.24
Flight Test (1.7hr Aircraft rental + Flight test fee \$450*)	\$722.00	\$756.00
Licensing fee(school AP fee + Transport Canada fee)	\$280.00	\$280.00
Total Estimated Cost:	\$29,451.24	\$32,585.24

* Flight test fee is subject to examiner

Night Rating

The Night Rating is usually the first rating a pilot acquires after the Private Pilot's Licence has been completed. Night flight has many advantages; the air is often calm with little or no turbulence, visibility is enhanced, there is usually less traffic. It is the most beautiful and peaceful time to fly. But we must be cautious... The horizon is obscure and there are also illusions unique to night flying. Therefore, you will have to acquire the skills necessary to fly with consistent cross reference to instruments. In addition, you will learn to fly with and without radio navigation aids as navigation is more difficult due to the lack of ground references.

Admission Requirements:

- Private Pilot License

Licensing Requirements:

Experience

You must have 20 hours minimum total Night Rating training consisting of at least

- 10 hours of non-instrument night flight time which includes
 - 5 hours of dual training with a minimum of 2 hours Cross Country
 - 5 hours of solo flying with a minimum of 10 take offs, circuits and landings
- 10 hours of dual instrument time of which 5 hours may be conducted in a flight simulator

Skill

Within the 12 months preceding the date of application for a night rating, an applicant must successfully complete a qualifying flight under the supervision of a holder of a flight instructor rating by demonstrating the level of skill specified in the Flight Instructor Guide-Aeroplane (TP 975).

Note: Prices are based on Transport Canada minimum requirements. Students may require additional flight training hours and ground briefing time. All prices are in CAD and are subject to change without prior notice. An hourly fuel surcharge will apply due to fuel price fluctuation.

This program does not require approval by the registrar of the Private Training Institutions Branch (PTIB) of the Ministry of Advanced Education, Skills & Training. As such, the registrar did not review this program.

	Training Costs		
	DA20-A1 @ \$160/hr solo \$233/hr dual	DA20-C1 @ \$180/hr solo \$253/hr dual	DA40 @ \$265/hr solo \$338/hr dual
10 hours Dual Flight Time	\$2,330.00	\$2,530.00	\$3,380.00
5 hours Solo Flight Time + instructor supervision (\$35/hr)	\$975.00	\$1,075.00	\$1,500.00
Licensing fee (school AP fee + Transport Canada fee)	\$90.00	\$90.00	\$90.00
Total Estimated Cost:	\$3,395.00	\$3,695.00	\$4,970.00

Multi-Engine Rating

The Multi-Engine Class Rating allows you to fly multi-engine aircraft with more complex systems. Considered mandatory by most Commercial Operations, the Multi-Engine Class Rating will also benefit the Private Pilot by allowing more operational capability and flexibility as to when and where to fly due to the additional safety of having two engines.

Course emphasis will be placed on advanced systems, multi-engine performance and emergency drills to ensure the required knowledge and skill is acquired for the student to confidently pilot an advanced multi engine aircraft.

Admission Requirements:

- Private Pilot Licence or higher

Licensing Requirements:

Skill

Within the 12 months preceding the date of application for the rating, an applicant for a Multi Engine Class Rating shall successfully complete a flight test to the standard outlined in the Flight Test Guide - Multi-Engine Rating.

Note: Students may require additional flight training hours and ground briefing time. All prices are in CAD and are subject to change without prior notice. An hourly fuel surcharge will apply due to fuel price fluctuation.

This program has been approved by the registrar of the Private Training Institutions Branch (PTIB) of the Ministry of Advanced Education, Skills & Training.

	Training Costs
	Diamond Twin Star DA42 TDI @ \$400/hr solo \$473/hr dual
5 hours Dual Training in the D-Sim-42 (G1000) Flight Training Device @ \$193/hr	\$965.00
7 hours Dual Flight Time on Twin Star DA42	\$3,311.00
9 hours Ground Briefing (\$73/hour)	\$657.00
SLA Multi-Engine Manual	\$40.00
Flight Test (1.2hr Aircraft rental + flight test fee \$450*)	\$930.00
Licensing fee	\$30.00
Total Estimated Cost:	\$5,933.00

* Flight test fee is subject to examiner

Multi Engine Instrument Rating

The Instrument Rating allows you to fly in cloud navigating solely by reference to the flight and navigation instruments. Building on the skills from your previous training you will learn to control the aircraft precisely "on the instruments" to fit in the air traffic system. As a result you will be able to fly safely when visual navigation is marginal or not possible.

Considered mandatory by most Commercial Operations, the Instrument Rating will also benefit the Private Pilot by allowing more capability and flexibility as to when to fly, and the background knowledge of man, environment and machine, to know when not to fly.

Building on your visual flight experience, the Instrument Rating definitely will take your flying to the next level.

Admission Requirements:

- Private Pilot Licence or higher

Licensing Requirement:

Prerequisites

You must hold a Multi Engine Rating.

Knowledge

You must obtain a minimum of 70% on the written examination Instrument Rating (INRAT)

Experience

You must obtain a minimum of:

- 50 hours of cross-country flight as pilot-in-command in aeroplanes of which 10 hours must be in the appropriate category.
- 40 hours of instrument time of which a maximum of 20 hours may be instrument ground time. The 40 hours instrument time shall include a minimum of:
 - 5 hours of dual instrument flight time acquired from the holder of a flight instructor rating.
 - 5 hours in a multi-engine aeroplane(non-centerline thrust) where the applicant is applying for a Group 1 instrument rating.
 - 15 hours of dual instrument flight time provided by a qualified person as specified in CAR425.21(9).
 - One dual cross-country flight under simulated or actual IMC conditions of a minimum of 100NM, the flight to be conducted in accordance with an IFR flight plan to include at, two different locations, an instrument approach to minima.

Skill

An applicant shall successfully complete a flight test in accordance with the Flight Test Standards - Instrument Rating (TP 9939E).

The cost for 50 hours of PIC cross country is not included in this estimate. All prices are in CAD and are subject to change without prior notice. An hourly fuel surcharge will apply due to fuel price fluctuation.

This program has been approved by the registrar of the Private Training Institutions Branch (PTIB) of the Ministry of Advanced Education, Skills & Training.

	Training Costs
	Diamond Twin Star DA42 TDI @ \$400/hr solo \$473/hr dual
20 hours Dual Training in the D-Sim-42 (G1000) Flight Training Device @ \$193/hr	\$3,860.00
12 hours Dual Flight Time (\$473/hour)	\$5,676.00
16 hours Ground Briefing (\$73/hour)	\$1,168.00
Written Examination	\$35.00
Flight Test (1.4hr Aircraft rental + Flight test fee \$450*)	\$1010.00
Licensing fee	\$30.00
Total Estimated Cost:	\$11,779.00

* Flight test fee is subject to examiner